



# DOC S

## CONTROL SLAVE UNIT



## USER MANUAL



**enormPA**



# Contents

<b>1. Safety and Maintenance</b> .....	<b>3</b>
<b>2. DQC-S Control Slave Unit</b> .....	<b>5</b>
<b>3. Controls, Connectors and Indicators</b> .....	<b>6</b>
3.1 Front Panel .....	6
3.2 Rear Panel .....	7
<b>4. Installation Instructions</b> .....	<b>11</b>
<b>5. Technical Specifications</b> .....	<b>12</b>
<b>6. Cable Connection Diagram</b> .....	<b>13</b>
<b>7. Block Diagrams</b> .....	<b>14</b>
<b>8. Certifications</b> .....	<b>16</b>
<b>9. Warranty Certificate</b> .....	<b>17</b>



## **IMPORTANT NOTICES**

- Before installing and using the device, please read this manual carefully and keep it for further use.
- This manual is an integral part of the product. It should be given to the new owner in order for them to know the installation, operation and safety instructions.
- Improper installation of the device removes the responsibility of the manufacturer.



## **WARNING**

- To avoid the risk of fire and electric shock, never expose this equipment to rain or moisture!



## **SAFETY PRECAUTIONS**

1. Please read the instructions carefully, as they contain important information.

2. The voltage of the power supply of this device has high values, which creates a risk of electric shock. For this reason, never install, connect or disconnect this product while the power supply is connected.

3. The metal parts of the product are grounded with an electric cable. If the electrical outlet that supplies electricity is not grounded, call a qualified electrician who will ground the product through the terminal.

4. To prevent damage to the cable, make sure the power supply cable is not crushed or broken.

5. To avoid the risk of electric shock, never open the product: there are no user fixable parts inside.

6. Make sure that foreign bodies or liquids do not come in contact with speakers, as this may cause short circuit.

7. Never try to perform repairs which are not mentioned in this manual. Contact the authorized service center or highly qualified personnel if;

- a. The product is not operating (or abnormally operating),
- b. Serious damage is done to the power supply cord,
- c. Foreign bodies or liquids get into the product,
- d. The product is exposed to heavy impact.

8. Turn off the product, if not used for a long time and disconnect the power supply cord.

9. If the product emits a strange odor or smoke, turn off immediately and disconnect the power supply cord.



## **PRECAUTIONS**

- Do not cover ventilation of the product.
- Do not allow amplifier to operate with an excessive load for a long time.
- Tighten the screws on the speakers firmly to guarantee safe contact.
- Do not use thinner, alcohol or other volatile substances when cleaning



## **CAUTIONS RELATED TO THE USE OF ELECTRICAL LINE**

- When plugging and unplugging the power cord, it should be held firmly to avoid risk.
- In case it won't be used for a long time, the plug of the unit should be unplugged to cut off the electricity.
- To avoid damaging the power cord, do not break, pull or harm the cord with sharp and pointy materials. Use a grounded socket.



## **POSITIONING**

- It should be placed with its sides and back 1 meter away from the wall and should not be placed in the following environments;
- Humid environment
- Under direct sunlight and other strong heat emitters
- Environments without ventilation



## **CONTROL OF THE UNIT**

- Make sure that the power supply is turned off, that the power supply and the other devices and lines connected with this unit are disconnected from the power supply.
- Do not remove this unit. Do not attempt to disassemble and fix this device yourself. Otherwise there may be a risk of electric shock or fire. If you can't solve the problems with the methods outlined later in this manual, you should call a qualified technician or consult our company. Enforcing the system could may electrical shock or fire.



## **CLEANING**

- When this unit needs to be cleaned, use a clean damp cloth etc. to dust. Do not use solvents such as benzene, thinner alcohol, strong volatile substances, bleach or other flammable liquids for cleaning the body of the unit.



## 2. DOC-S CONTROL SLAVE UNIT

The EnormPA DOC system is fully compliant with European Standard EN 54-16 and meets all requirements for emergency voice alarm control and indicating equipment. DOC-S is used as the zone expander of a 16-channel or 8-channel system.

DOC8 or DOC16 is an Ethernet-based PA/VA system that can be used with up to 8 or 16 channels respectively. DOC-S is the slave unit with the same features, used when there are more zones than those available on the main control unit. Designed to operate even in decentralized systems, this system is not only fully reliable, but also enables high-safety operations required in all emergency tasks, such as switching to the backup power amplifier, fault detection and indication, real-time speaker line impedance monitoring, and open/short circuit detection. Thanks to the latest "multi-connectivity" application, there are no limits in communication and flexibility. All inputs and outputs are fully programmable and allow automated or pre-scheduled announcements to be delivered to selected zones. The ESCO-DOC system can be easily integrated and, thanks to its plug-and-play philosophy, installation, maintenance and operating costs are significantly reduced.

Detailed functions and features are listed below.

### 2.1 Device Characteristics

- ▶ Indicates status via front-panel LEDs.
- ▶ Includes 16 defined A-B zones.
- ▶ Includes 2 external stereo inputs and 1 music server input (for example MS40).
- ▶ Supports speaker-line monitoring and ground fault detection.
- ▶ The main power supply is protected by a fuse.
- ▶ Includes a built-in speaker for zone monitoring.
- ▶ Up to 3 source files can be played over the network or from internal files.
- ▶ Supports switching between amplifiers.
- ▶ Supports self-test and automatic fault detection.
- ▶ Zone and source names can be defined via the interface.
- ▶ Supports broadcasting via scheduled tasks.
- ▶ The system can be expanded up to 64 zones with DOC-S.
- ▶ Monitored and recordable logs are kept in the system.
- ▶ Except in emergencies, supports storing announcements and messages in memory and broadcasting them according to the assigned priority.
- ▶ Includes DSP module.
- ▶ Uses RS485 protocol for external communication.

## 2.2 Device Functions & Features

- ▶ Main and backup power supply
- ▶ Power source protection
- ▶ Speaker line fault detection
- ▶ Monitoring/tracking function
- ▶ Self-test function
- ▶ Power amplifier management
- ▶ Emergency voice alarm function
- ▶ Public address function
- ▶ MP3 file broadcasting feature
- ▶ Configuration through the interface
- ▶ Monitoring through the interface
- ▶ Simple settings and cross-check feature through the interface

## 3. Controls, Connectors & Indicators

### 3.1 Front Panel

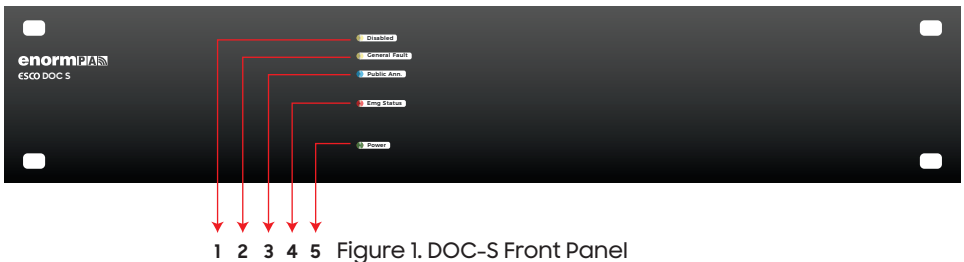

1 2 3 4 5 Figure 1. DOC-S Front Panel

**1. Disabled LED:** Lights yellow when the related function ("Disabled") is selected from the interface. In this status, tests for finding faults according to EN54-16 are not performed and all related functions are disabled. This function is used if the system installation is not compliant with EN54-16.

**2. General Fault LED:** Lights when any fault exists in the system. The fault status can also be seen on the LCD screen. The yellow LED turns off when all system components operate correctly.

**3. Public Announcement LED:** Lights when the device is stable. In any emergency, this yellow LED turns off and the Emg Status LED lights.

**4. Emg Status LED:** Lights when an emergency occurs. The red LED lights when an announcement is made from the emergency microphone or when an Alarm or Alert message is being broadcast.

**5. Power LED:** Lights when the device has 220VAC power. The green LED turns off when mains (220VAC) power is not available.

### 3.2. Rear Panel

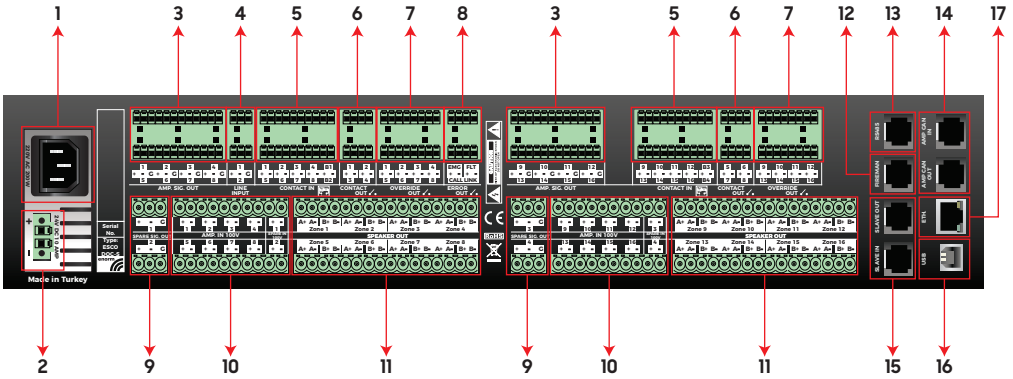

Figure 2. DOC-S Rear Panel

**1. 220V AC 220W:** 220VAC mains input socket. The mains supply must be grounded.

**2. 24V DC 10A:** Backup battery (24VDC) connection input socket. If the installed system is required to meet EN54-16 requirements, this input must be supplied by an EN54-4 certified power supply.

Note: When connecting the battery, observe the "+" and "-" polarities on the device.

**3. Amp Sig Out:** Balanced amplifier signal outputs. Pay attention to the channel number from which the amplifier signal output is taken from the DOC-S. This number will later be used when feeding the signal through Amplifier In 100V (10). If any fault occurs in the amplifiers connected to these inputs/outputs, the system detects the fault and automatically routes the signal to these inputs/outputs via Spare Sig Out (9). Routing settings can be managed from the web interface.

**4. Line Input:** Section for connecting music sources. Two music sources can be connected. The connection may be balanced or unbalanced. Please refer to the figures below.

Balanced connection type:



Figure 3. Balanced line input connection diagram

Unbalanced connection type:

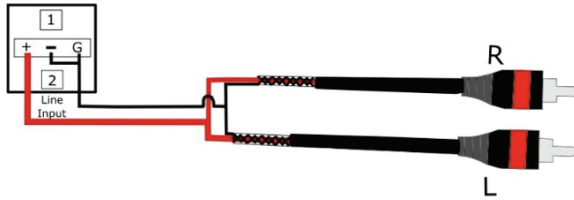

Figure 4. Unbalanced Line input connection diagram

**5. Contact In:** Section containing static contact inputs. When a numbered contact input is activated, the Alarm message is transmitted to the output with the same number in the Speaker Out (11) section, while the Alert message is transmitted to the other zones. There are 16 static and 4 programmable business (B1, B2, B3, B4) dry contacts. Any MP3 file can be uploaded to all contacts via the web interface. Business contacts can be grouped by zones. If there is a problem with the cables connected to the activated contact terminals, a General Fault error will be displayed. To locate the fault, the cable connections must be compliant with EN54-16 standards. Please see Figure 5 below.

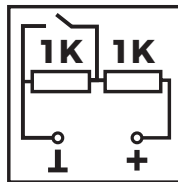

Figure 5. Contact cable connection diagram

**6. Contact Out:** 8 programmable dry contact outputs. Programmable through the interface software.

**7. Override Out:** 16 dry contact outputs. Activated when the Contact In inputs are triggered.

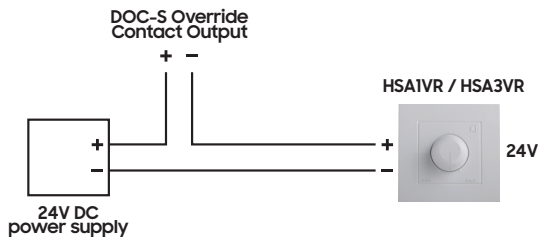

Figure 6. Contact connection diagram

**8. Error Out:** Section containing fault output contacts. There are 4 different fault output contacts.

**a. EMG:** Activated when Contact In receives a signal, when the Alarm and Alert buttons are pressed, or when an emergency announcement is initiated from the EMG microphone.

**b. FLT:** Activated when any fault occurs in the system or devices.

**c. Call:** Activated when any announcement is made from the MA5 microphone console.

**d. Link:** Activated when a connection fault occurs on communication-capable devices connected to the DOC-S.

**9. Spare Sig Out:** Balanced audio signal output for up to four amplifiers connected to the system. It becomes active if one or more of the main amplifiers fail.

**10. Amp In 100V / Spare In 100V:** Input used to connect the 100 V audio output of the main and backup amplifiers. Inputs No. 1&5 are used for announcements and No. 2&6 for music amplifiers. The remaining inputs (3, 4, 7 and 8) can be used and configured as desired. The same logic applies to the contacts numbered 9 to 16 on the right side of the device. For the connection between DOC-S and the amplifier (D4250IP), see the connection diagram in Figure 11. X and Y represent contacts from 1 to 16. For more detailed information, see Schematic 1.

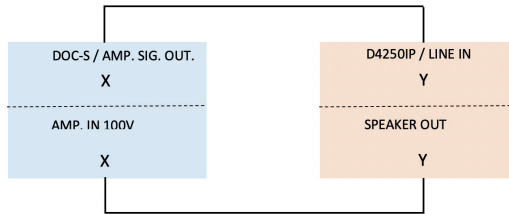

Figure 7. DOC-S - D4250IP connection diagram

For the signal going to the amplifier: whichever number ("X") is used for the output from AMP. SIG. OUT on the DOC-S, the signal coming from the amplifier must be fed into the same number ("X") in AMP. IN 100V on DOC16. The same applies to the signal going to and coming from the amplifier. Examples are given below.

**Example 1:**

DOC-S AMP. SIG. OUT 1 → D4250IP LINE IN 2

D4250IP SPEAKER OUT CH2 → DOC-S AM. IN. 100V 1

**Example 2:**

DOC-S AMP. SIG. OUT 5 → D4250IP LINE IN 3

D4250IP SPEAKER OUT CH3 → DOC-S AM. IN. 100V 5



**11. Speaker Out:** Local speaker audio outputs configurable by the operator. There are 16 A/B speaker outputs.

**12. RS485:** Input for serial communication protocol.

**13. Amp Can In / Amp Can Out:** Communication input and output for amplifiers connected to the system.

**14. Fireman:** Input for communication with the fire panel.

**15. Slave In / Slave Out:** Communication input and output for DOC Slave devices used to increase the number of zones. Please connect in accordance with the patch cable connection.

**16. USB:** USB socket for configuring DSP features.

**17. Eth:** 0 Mb - 100 Mb Ethernet switch.

## 4. Installation Instructions

The DOC-S control unit is suitable for desktop or 19-inch rack cabinet installation. When positioning the device, to ensure trouble-free operation, the ventilation openings on both sides of the chassis must not be blocked and the device must be screwed to the rack cabinet from all four corners. Therefore, make sure there is sufficient clearance around the side walls of the device when placing it on a desktop or in a rack cabinet.

To prevent bending of the front panel or impacts on the panel, it is recommended to use mounting rails when installing the device in a rack or cabinet.

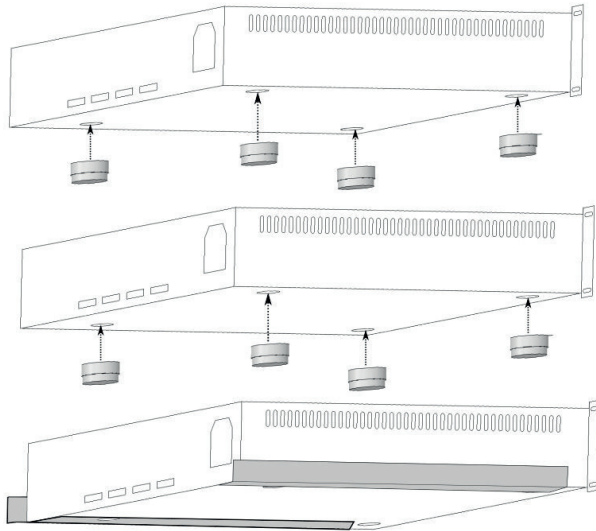

Figure 8. Stacking the Devices



If the devices are to be stacked in a rack, the maximum load of the mounting rails must be taken into account. Please refer to the manufacturer's technical notes. To prevent damage to the devices, it is recommended to use the supplied adhesive feet.

To start the system, please refer to the cable configuration between the control unit and the connected devices in the diagrams below.

1. After all connections are made according to the diagrams, connect power (220VAC) to input No. 1 (Fig. 6) on the rear panel of the DOC-S device.
2. Wait for the device to start until it completes the necessary checks. Startup takes approximately 3 minutes.
3. If the fault LED on the front panel of the device is not lit, it is ready for use.

DOC-S is now ready for use.

## 5. Technical Specifications

### DOC-S Control Slave Unit

SECTION	SPECIFICATION
Control and indicators	<b>Front panel:</b> Status indicator LEDs; monitoring LEDs.
Rear connections	<b>Power / network:</b> AC power socket; 24 V battery input; 1 x Ethernet 10/100M WAN/LAN. <b>Control buses:</b> 1 x Fireman Out RS485; 2 x CANBUS In/Out; 2 x Slave Connection CANBUS; 1 x RS485; 1 x USB (DSP programming). <b>Audio / I/O:</b> 2 line inputs; 16 sound-signal outputs; 4 spare-amplifier outputs; 16 + 4 amplifier inputs (100 V). <b>Contacts / zones:</b> 4 error outputs; 8 contact outputs; 16 override outputs; 16 contact inputs; 16 speaker outputs.
Electrical	<b>Main power supply:</b> 160/230 VAC, 50/60 Hz. <b>Power consumption:</b> 200 W. <b>Mains fuse:</b> 6 A.
Battery power supply	<b>Voltage:</b> 21.5-28.5 VDC. <b>Internal fuse:</b> 10 A.
Performance	<b>DSP / sampling:</b> Integrated 48 kHz / 24-bit processing, 344 MIPS. <b>SNR:</b> >75 dB. <b>THD:</b> <0.03%.
Line inputs	<b>Channels:</b> 2 <b>Connectors:</b> 2 x 3-pin Phoenix <b>Input signal:</b> -40 dBV to 0 dBV. <b>Input impedance:</b> 10 kOhm.
Line outputs	<b>Output channels:</b> 16; spare amplifier output channels: 4. <b>Connectors:</b> 3-pin Phoenix. <b>Output signal:</b> <1.6 dBV (1.2 V). <b>Output impedance:</b> <100 Ohm.
Contact inputs	<b>Input rating:</b> 3 A per channel. <b>Standard inputs:</b> 16 line-monitored channels. <b>Connectors:</b> Euroblock type.
Contact outputs	<b>Programmable outputs:</b> 8 channels, 10 A per channel. <b>Override outputs:</b> 16 channels, 10 A per channel. <b>Error outputs:</b> 4 channels - EMG, FLT, CALL and LINK.
Amplifier line inputs	<b>Main amplifier inputs:</b> 16 x 50 V or 100 V, each max. 300 W. <b>Backup amplifier inputs:</b> 2 x 100 V, each max. 600 W. <b>Connectors:</b> Euroblock type.
Speaker line outputs	<b>Zones:</b> 16 supervised A/B speaker-line outputs. <b>Connectors:</b> A/B Euroblock type.
Mechanical	<b>Dimensions (H x W x D):</b> 2U, 88 x 483 x 455 mm. <b>Weight:</b> 12 kg (26.45 lb). <b>Colour:</b> RAL 7016.
Environmental factors	<b>Operating temperature:</b> -5°C to +45°C (23°F to 113°F). <b>Relative humidity:</b> 5% to 95%, non-condensing.
Package contents	<b>Supplied items:</b> 1 male Euroblock-type connector; 1 PTT microphone; 40 x 1 kOhm resistors; 1 EU power cable (2 m); 1 Ethernet cable; 1 Mikafon Enorm Software GUI; 1 user manual.

## 6. Cable Connection Diagram

Figure 9 shows sample cable connections for a scenario with 9 DOC16 units.  
Example 1

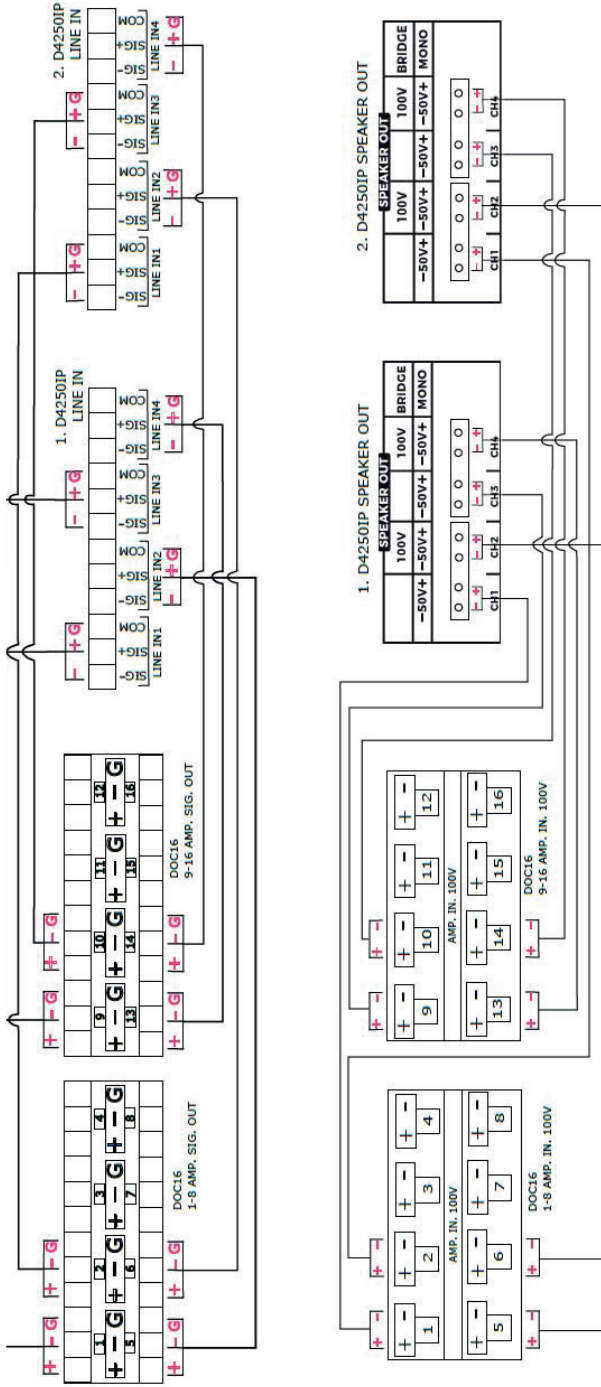

Figure 9 DOC16 / D4250IP connection diagram

The example above shows the mono connection type for two D4250IP units and the connection layout for one D4250IP. Please refer to the related DOC / D4250IP operating instructions before commissioning.

The same logic applies for DOC16 connections with DOC-S.

\*D5240IP is designed to operate together with DOC16 and the EN54-16 system.

# DOC-8/16 BLOCK DIAGRAM

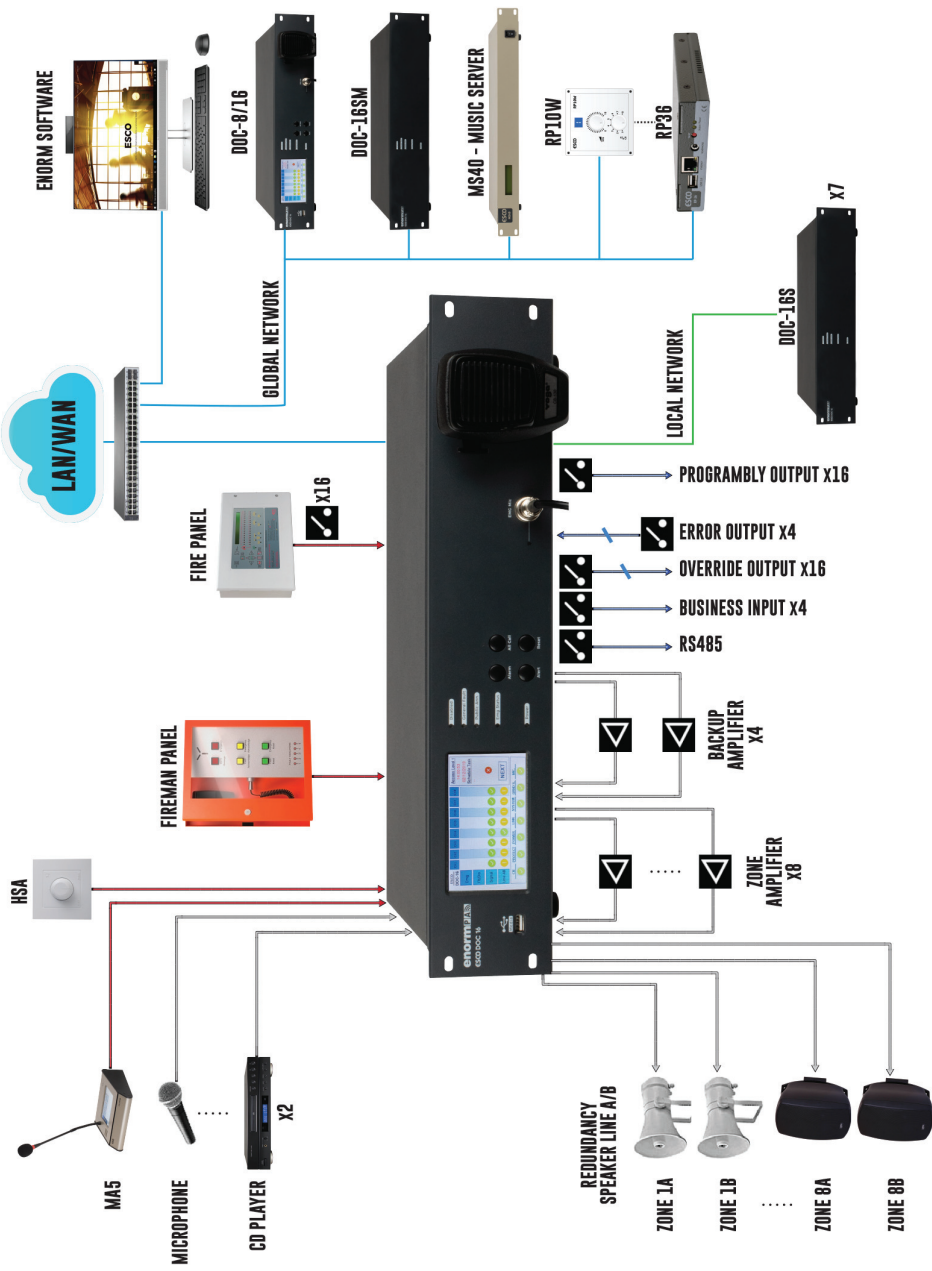

# DOC-8/16 BLOCK DIAGRAM

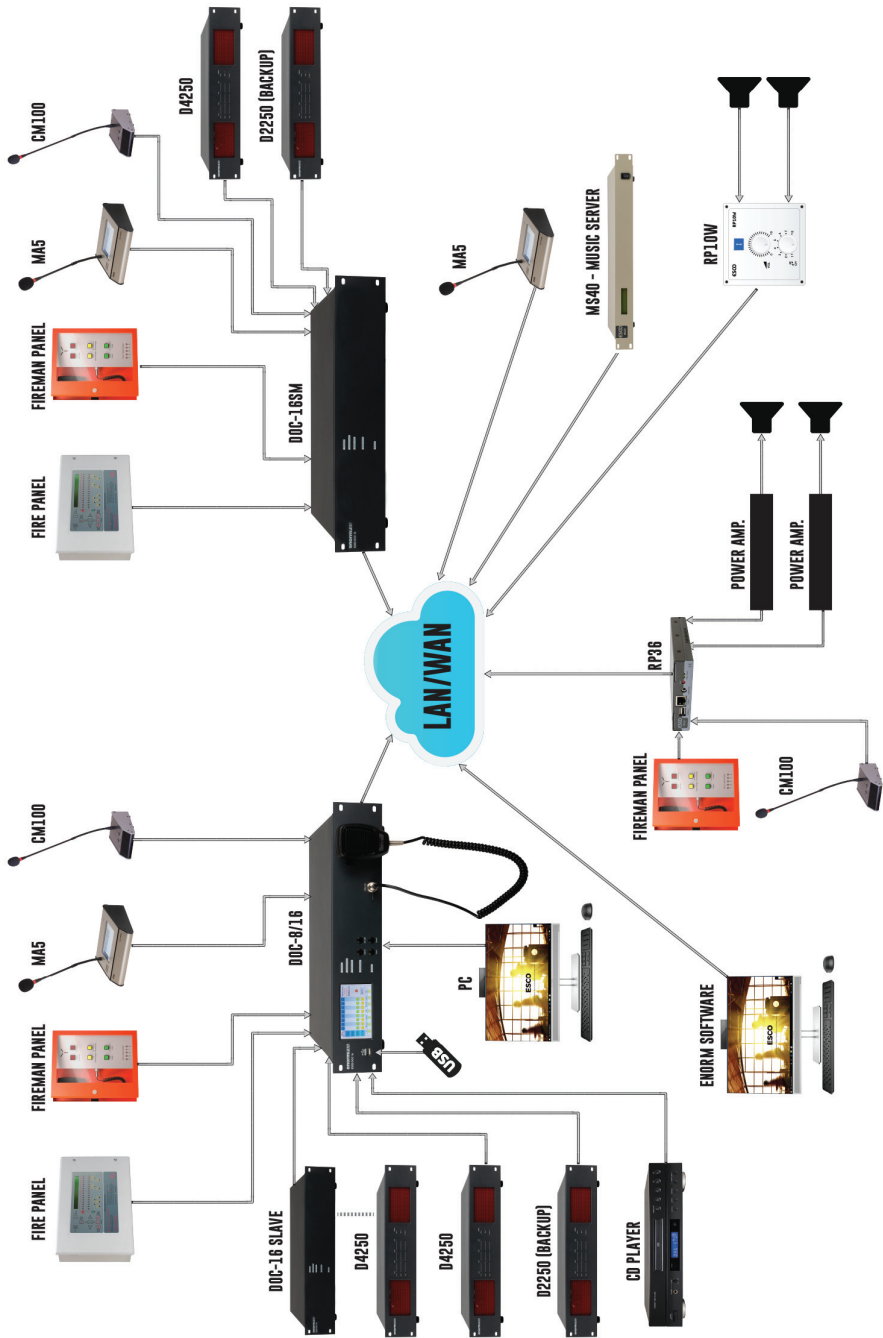

**EC DECLARATION OF CONFORMITY**

Type of Product	Reference	Brand:	Model Name	Description
PAVA	15950370	EnormPA	ESCO/DOC 8	8 Zone-Voice Alarm Sys. Manager,TCP IP
PAVA	15950380	EnormPA	ESCO/DOC 16	16 Zone-Voice Alarm Sys. Manager,TCP IP
PAVA	15950385	EnormPA	ESCO/DOC 16S	16 Zone-Voice Alarm Sys.Slave,TCP IP

is in conformity with Directives:

2014/35/EU - Low Voltage Directive (LVD)

2014/30/EU - Electromagnetic compatibility (EMC)

2011/65/EU - Restriction of the use of certain hazardous substances (RoHS 2)

according to the provisions for compliance:

EN54-16 :2008

**This declaration of conformity is issued under the sole responsibility of the manufacturer:**

**Name Of Manufacturer:** MİKAFON ELEKTRONİK İNŞ.SAN.LTD.ŞTİ.

Şair Ziya Paşa Cad No: 8 34420 Karaköy - İSTANBUL / TURKEY

**Signed for and on behalf of the manufacturer by:**

Name: Ercan Polat

Position: General Manager

Istanbul, January 01 2021

**MİKAFON ELEKTRONİK  
İNŞAAT SAN. VE TİC. LTD. ŞTİ.**  
Şair Ziyapaşa Cd. No: 8 Karaköy-İST.  
Yenikapı V.D. 0210 67 6443

# WARRANTY GARANTİ BELGESİ

Bu belgenin kullanılmasına; 4077 sayılı Tüketicinin Korunması Hakkında Kanun ve bu Kanun'a dayanılarak yürürlüğe konulan Garanti Belgesi Uygulama Esaslarına Dair Yönetmelik uyarınca, T.C. Sanayi ve Ticaret Bakanlığı İl Müdürlüğü tarafından izin verilmiştir.

## İMALATÇI FİRMANIN

ÜN VANI: MİKAFON ELEKTRONİK İNŞ.SAN.LTD.ŞTİ.  
MERKEZ ADRESİ: Şair Ziya Paşa Cad. No: 8/A 34420 Karaköy / İSTANBUL  
TELEFON: 0(850) 450 18 63 (Dahili: 210)  
FAKS: 0 212 244 5175



## MALIN

CİNSİ: CONTROL SLAVE UNIT  
MARKASI: **enorm**

MODELİ:  
SERİ NO:

GARANTİ SÜRESİ: 2 (İKİ) YIL ————— WARRANTY: 2 (TWO) YEARS VALIDITY  
AZAMİ TAMİR SÜRESİ: 30 (OTUZ) İŞ GÜNÜ ————— MEAN TIME TO REPAIR: 30 (THIRTY)  
WORK DAYS

## SATICI FİRMANIN

ÜN VANI: \_\_\_\_\_  
ADRESİ: \_\_\_\_\_

TELEFONU: \_\_\_\_\_  
FAKSI: \_\_\_\_\_  
FATURA TARİH VE NO: \_\_\_\_\_ / \_\_\_\_\_

TARİH-İMZA-KAŞE:



**enormPA** 

---

**MİKAFON ELEKTRONİK İNŞ. SAN. LTD. ŞTİ.**

**Showroom:** Şair Ziya Paşa Cad. No: 8/A 34420 Karaköy / İSTANBUL

**Ara Depo:** Çatma Mescit Mah. Mektep Sok. No:8 Şişhane-Beyoğlu / İSTANBUL

**Fabrika / Depo:** Cumhuriyet Mah. Keten Sok. Şekerpinar-Çayırova / KOCAELİ

**Telefon:** +90 212 244 5177 (pbx) | **GSM:** +90 533 657 8175 | **Faks:** +90 212 244 5175

**E-posta:** [info@mikafon.com.tr](mailto:info@mikafon.com.tr) | [www.mikafon.com.tr](http://www.mikafon.com.tr)

